



FIFA Quality Programme for Football Goals

How to obtain a certification for
football goals

December 2020 | Version 1.0



Introduction

The International Football Association Board (IFAB) defines the dimensions and key characteristics of football goals in the Laws of the Game under Law 1, The Field of Play.

10. Goals

A goal must be placed on the centre of each goal line.

A goal consists of two vertical posts equidistant from the corner flagposts and joined at the top by a horizontal crossbar. The goalposts and crossbar must be made of approved material. They must be square, rectangular, round or elliptical in shape and must not be dangerous.

The distance between the inside of the posts is 7.32 m (8yds) and the distance from the lower edge of the crossbar to the ground is 2.44 m (8ft).

The position of the goalposts in relation to the goal line must be in accordance with the graphics.

The goalposts and the crossbar must be white and have the same width and depth, which must not exceed 12 cm (5 ins).

If the crossbar becomes displaced or broken, play is stopped until it has been repaired or replaced in position. If it can not be repaired the match must be abandoned. A rope or any flexible or dangerous material may not replace the crossbar. Play is restarted with a dropped ball.

Nets may be attached to the goals and the ground behind the goal; they must be properly supported and must not interfere with the goalkeeper.

Safety

Goals (including portable goals) must be firmly secured to the ground.

11. Goal line technology (GLT)

GLT systems may be used to verify whether a goal has been scored to support the referee's decision.

Where GLT is used, modifications to the goal frame may be permitted in accordance with the specifications stipulated in the FIFA Quality Programme for GLT and with the Laws of the Game. The use of GLT must be stipulated in the competition rules.

The FIFA Quality Programme for Football Goals was launched in November 2020 with the aim of further defining the safety and performance characteristics of football goals and ensuring compliance with the highest standards demanded by a number of competition organisers.

The tests are performed by accredited independent test institutes, and certified football goals are listed on the Football Technology Innovation website www.football-technology.fifa.com for end-user guidance.

The following document is a comprehensive guide for any company seeking to test and certify its football goals to the requirements of the FIFA Quality Programme.

Application process and checklist

The application process for the company and the goal tests is outlined below. Note that each step must be completed before the next one can be started. In total, the application process can take up to five months.

1	Applicant	Application Documents 1 Company profile – Template (see 1.1) + Company Registration Document 2 WFSGI pledge – process to be handled with WFSGI directly through pledge@wfsgi.org (see 1.2) 3 General and product liability insurance (see 1.3) 4 ISO 9001 (see 1.4) 5 Details of the goal that is to be tested – Template (see 1.5)
	FIFA	FIFA will confirm receipt and review the documents
2	Applicant	Product testing 6 Send products for testing to the selected test institute (2.0). The test institute will send the test results to FIFA. 7 Pay the test fee directly to the test institute
	FIFA	FIFA will review the test results and confirm the result of the testing. If the result is positive, continue to step 3 of the process
3	FIFA	Licence agreement FIFA provides a licence agreement via DocuSign
	Applicant	8 Review of the agreement <ul style="list-style-type: none"> • Contact FIFA in case of any questions • The contract will be signed and returned to FIFA via DocuSign
4	Applicant	Finalisation of licence agreement Applicant will pay the contract fee as per the invoice issued by FIFA after the conclusion of step 3 of the licensing process
	FIFA	After receipt of the payment, FIFA will: <ul style="list-style-type: none"> • List the company as a FIFA licensed provider on the FQP website • List the tested products on the FQP website as certified products • Provide access to the FQP 4.0 database • Provide access to the FIFA Digital Archive for access to the relevant FIFA Quality marks

Step 1: Application documents

1.1. Company profile

Each applicant shall provide the following company details as per the table below. Please fill this template out carefully as it will be used as the basis for the Licence Agreement.

Company profile	
Full name of the legal entity	
Official trading name	
Legal address	
Main business	
Main contact person	
Name of person(s) required and authorised to sign	
Email address	
Phone number	
Third-party manufacturer(s) (e.g. for the manufacturing of the posts or nets)	

1.2. WFSGI Pledge

The World Federation of the Sporting Goods Industry (WFSGI) Pledge confirms that FIFA-certified goals have been produced in compliance with globally recognised labour principles. The pledge must be obtained on an annual basis and can be requested directly from the WFSGI (pledge@wfsgi.org). When contacting the WFSGI, please refer to the FIFA Quality Programme for Football Goals. The cost of the pledge is composed of an administration fee, payable to the WFSGI, and the audit costs of the independent social auditor.

The WFSGI Pledge is valid for one year and must be renewed on an annual basis in order for the FIFA licence and goal approval to remain valid.

Note: a separate pledge approval is requested for each individual place of production.

1.3. General and product liability insurance

As a prerequisite to becoming a FIFA licensee, each applicant must have product liability insurance (PLI) and general liability insurance, and it is mandatory for both to be valid for the entire term of the contract. Both insurances are primarily in the interest of the licensee itself. If the licensee's national insurance market does not provide adequate insurance solutions, it is helpful and constructive to use an insurance broker with access to the international insurance market. The applicant must provide written confirmation from the insurance company that the product liability insurance (PLI) meets the following criteria:

Product liability insurance – minimum requirements

1	Name and address of licensee (policyholder)
2	Territorial scope of application: worldwide coverage needed (incl. USA & Canada), no exclusion allowed
3	Period – coverage needed throughout whole contract period
4	FIFA must be named as a co-insured party
5	Coverage: a minimum of CHF 5 million per claim for bodily injuries, property damages and pure financial losses

Please bear in mind that the application process can take up to five months – therefore, we recommend defining the start date of the insurance closer to the signing of the Licence Agreement.

For an example of a policy, see Annexe 2.

1.4. ISO 9001

The ISO 9001 specifies requirements for the quality management system of an organization. To demonstrate the ability to consistently provide products and services that meet customer and applicable regulatory requirements each FIFA licensee has to be ISO 9001¹ certified.

1.5. Details of the goal

Please provide the following information of the goal sent to the test institute for initial testing:

Product information			
Goal type	<input type="checkbox"/> Fixed goal <input type="checkbox"/> Mobile goal	Certificate	<input checked="" type="checkbox"/> FIFA Quality
Goal name		Serial number	
Goal manufacturer		Net manufacturer	

¹ Until 31 December 2021 applicants can become a licensee if they have started the ISO 9001 certification process. In this case, the certificate has to be provided within the first 6 month of the term of the license agreement.

Step 2: Product testing

Samples to be sent to the test institute

For the product testing and certification, the following samples must be sent to the selected FIFA accredited test institute:

- Goalposts, netting and all auxiliary components used in a complete match set-up
- A schematic of the post cross-sectional profile, such as shown opposite
- A goal net or sample of sufficient size so as to allow 10x tensile samples to be obtained
- Net head line sample of at least two metres in length
- Any other relevant information which may be of use, manuals, maintenance & inspection instructions

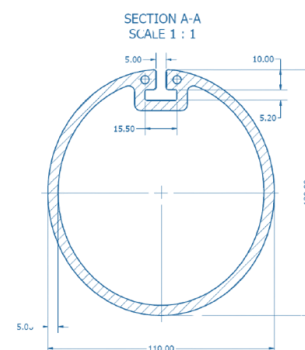

The testing will take approximately three weeks from the arrival of the product until the time that FIFA provides the test results, depending on the capacity of the test institute.

A list of the accredited test institutes can be found [here](#) (as of December 2020).

FIFA will notify the applicant of the test results as soon as they have been received from the accredited test institute. FIFA will then provide the standard Licence Agreement if the test results are positive.

Steps 3 and 4: Licence Agreement

To certify their football goals to one of the FIFA standards for football goals, manufacturers have to sign a Licence Agreement with FIFA. FIFA offers three contract options:

- FIFA Basic licence²: for manufacturers who want to certify their products to the FIFA Basic standard
- FIFA Standard licence: for manufacturers who want to certify their products to one of the existing standards: FIFA Basic, FIFA Quality or FIFA Quality Pro
- FIFA Preferred Provider³: additional licence for well-established manufacturers with a Standard licence who would like to have additional marketing rights

² The FIFA Basic licence is, at the time of publication of this document, still in development and will be available as of June 2021

³ The FIFA Preferred Producer licence is only available for companies with a track record of at least two years as a FIFA Standard licensee

Licence Agreement details	
Contract period	4 years
Product liability insurance	Required
General liability insurance	Required
WFSGI Pledge	Required
Quality marks	FIFA Basic licence: FIFA Basic FIFA Standard licence: FIFA Basic, FIFA Quality, FIFA Quality Pro FIFA Preferred Provider: FIFA Basic, FIFA Quality, FIFA Quality Pro, FIFA Preferred Producer logo

Please note that the Licence Agreement will only become effective once both parties have signed. Upon the finalisation of the Licence Agreement, the licensee will receive the following:

- Invoice for the licence fee (if applicable), payable within 30 days after full execution of the contract
- Access to the **FIFA Digital Archive** to download the respective quality marks
- Access to the **FIFA Quality Programme database** to administrate their products and contract

Annexe 1: Frequently Asked Questions

I am a distributor of football goals, can I become a FIFA Licensee?

The FIFA Quality Programme for Football Goals is only open to manufacturers of football goals. Distributors of football goals are not eligible to become a licensee.

I have a quality assurance process in place. Do I still need the WFSGI Pledge?

Yes, each manufacturer is required to provide the WFSGI Pledge. Without this, the Licence Agreement cannot be signed, and it will automatically terminate if the pledge is not renewed for the subsequent years of the agreement. For the WFSGI Pledge form or any further information, please contact the WFSGI by email pledge@wfsgi.org or by calling +41 31 939 60 61. The typical procedure is as follows:

Step 1	Request the WFSGI Pledge form from the WFSGI (pledge@wfsgi.org)
Step 2	Complete and sign the WFSGI Pledge form, submit a social audit and return to WFSGI
Step 3	WFSGI will verify compliance with WFSGI Code of Conduct
Step 4	If WFSGI requirements are met, the WFSGI will charge an administration fee
Step 5	Once the administration fee has been paid, the WFSGI will send confirmation of the pledge to FIFA

Can FIFA recommend an insurer for the product liability insurance?

FIFA cannot recommend any individual company. Generally, large international insurance companies will be able to provide the necessary cover and policy. Please note that to date this has been possible in every territory worldwide, so please contact several insurers if you do not obtain the requested cover.

What happens if my goal fails just one criterion or one value?

If a goal fails any single criterion or value – irrespective of nature of the fail – the whole test is considered failed. A full re-test of the goal is required. Partial tests or re-tests are not possible.

Annexe 2: Example of product liability insurance*

CERTIFICATE OF INSURANCE

To: whom it may concern

The “ INSURANCE COMPANY XYZ ” hereby certifies that a liability coverage is currently held by Licensee, under Address of Licensee, International Global Insurance Program No. _____ and Certificate No. _____ with the following terms and conditions:

General Liability Limits:

Public Liability / Products Liability annual aggregate limited to

- Public Liability per occurrence
- Products Liability per occurrence/ annual aggregate

CHF 5'000'000.00

Coverage Term

Inception: midnight 31.12.2013
Expiration: midnight 31.12.2014

Policy Territory: Worldwide.

FIFA is named as **Additional Insured**, under the Product Liability section, only for the liability arising out from licence agreement related to the use of the trademark “**FIFA Quality**” and “**FIFA Quality Pro**” by _____, up to a sublimit **CHF 5'000'000.00** per occurrence

This certificate or verification of insurance is not an insurance policy and does not amend extend or alter the coverage afforded by the policy listed herein. Notwithstanding any requirement, term or condition of any contract or other document with respect to which this certificate of verification of insurance may be issued or pertain, the insurance afforded by the policy herein is subject to all terms, conditions and exclusions of such policy.

Insurance Company Name
Signature
Stamp

Issued in City on Date, in 2 copies.

1/1



* The above document is an example of a PLI coversheet for guidance only.